

# EOLX-1596-40X series

## 10G XFP Transceiver

### Features

- ◆ Supports 9.95Gb/s to 11.1Gb/s bit rates
- ◆ Hot-pluggable XFP footprint
- ◆ Maximum link length of 40km
- ◆ Temperature-stabilized DWDM rated EML transmitter
- ◆ Duplex LC connector
- ◆ Power dissipation <3.5W
- ◆ Built-in digital diagnostic functions
- ◆ Temperature range -5°C to 70°C



### Applications

- ◆ 10GBASE-ER/EW 10G Ethernet
- ◆ 1200-SM-LL-L 10G Fibre Channel
- ◆ SONET OC-192 IR-2
- ◆ SDH STM S-64.2b
- ◆ SONET OC-192 IR-3
- ◆ SDH STM S-64.3b
- ◆ ITU-T G.709



<b>Channel</b>	<b>Part NO.</b>	<b>Frequency (THz)</b>	<b>Center Wavelength (nm)</b>
17	EOLX-1596-4017	191.7	1563.86
18	EOLX-1596-4018	191.8	1563.05
19	EOLX-1596-4019	191.9	1562.23
20	EOLX-1596-4020	192.0	1561.42
21	EOLX-1596-4021	192.1	1560.61
22	EOLX-1596-4022	192.2	1559.79
23	EOLX-1596-4023	192.3	1558.98
24	EOLX-1596-4024	192.4	1558.17
25	EOLX-1596-4025	192.5	1557.36
26	EOLX-1596-4026	192.6	1556.55
27	EOLX-1596-4027	192.7	1555.75
28	EOLX-1596-4028	192.8	1554.94
29	EOLX-1596-4029	192.9	1554.13
30	EOLX-1596-4030	193.0	1553.33
31	EOLX-1596-4031	193.1	1552.52
32	EOLX-1596-4032	193.2	1551.72
33	EOLX-1596-4033	193.3	1550.92
34	EOLX-1596-4034	193.4	1550.12
35	EOLX-1596-4035	193.5	1549.32
36	EOLX-1596-4036	193.6	1548.51
37	EOLX-1596-4037	193.7	1547.72
38	EOLX-1596-4038	193.8	1546.92
39	EOLX-1596-4039	193.9	1546.12
40	EOLX-1596-4040	194.0	1545.32
41	EOLX-1596-4041	194.1	1544.53
42	EOLX-1596-4042	194.2	1543.73
43	EOLX-1596-4043	194.3	1542.94
44	EOLX-1596-4044	194.4	1542.14
45	EOLX-1596-4045	194.5	1541.35
46	EOLX-1596-4046	194.6	1540.56
47	EOLX-1596-4047	194.7	1539.77
48	EOLX-1596-4048	194.8	1538.98
49	EOLX-1596-4049	194.9	1538.19
50	EOLX-1596-4050	195.0	1537.40
51	EOLX-1596-4051	195.1	1536.61
52	EOLX-1596-4052	195.2	1535.82
53	EOLX-1596-4053	195.3	1535.04
54	EOLX-1596-4054	195.4	1534.25
55	EOLX-1596-4055	195.5	1533.47
56	EOLX-1596-4056	195.6	1532.68
57	EOLX-1596-4057	195.7	1531.90



58	EOLX-1596-4058	195.8	1531.12
59	EOLX-1596-4059	195.9	1530.33
60	EOLX-1596-4060	196.0	1529.55
61	EOLX-1596-4061	196.1	1528.77

## Absolute Maximum Ratings

Parameter	Symbol	Min	Typ	Max	Unit	Ref.
Maximum Supply Voltage 1	Vcc3	-0.5		4.0	V	
Maximum Supply Voltage 2	Vcc5	-0.5		6.0	V	
Storage Temperature	TS	-40		85	°C	
Case Operating Temperature	TOP	-5		70	°C	

## Recommend operating condition

Parameter	Symbol	Min	Typ	Max	Units	Ref.
Operating Temperature	Top	-5		70	°C	
Supply Voltage 1	Vcc3	3.13	3.3	3.45	V	
Supply Voltage 2	Vcc5	4.75	5	5.25	V	

## Electrical Characteristics

(TOP = -5 to 70 °C, VCC5 = 4.75 to 5.25 Volts)

Parameter	Symbol	Min	Typ	Max	Unit	Note
Main Supply Voltage	Vcc5	4.75		5.25	V	
Supply Voltage #2	Vcc3	3.13		3.45	V	
Supply Current – Vcc5 supply	Icc5			300	mA	
Supply Current – Vcc3 supply	Icc3			750	mA	
Module total power	P			3.5	W	
Transmitter						
Input differential impedance	Rin		100		Ω	1
Differential data input swing	Vin,pp	120		820	mV	
Transmit Disable Voltage	VD	2.0		Vcc	V	
Transmit Enable Voltage	VEN	GND		GND+0.8	V	
Transmit Disable Assert Time				10	us	

Receiver						
Differential data output swing	Vout,pp	340	650	850	mV	
Data output rise time	tr			38	ps	2
Data output fall time	tf			39	ps	2
LOS Fault	VLOS fault	Vcc – 0.5		VccHOST	V	3
LOS Normal	VLOS norm	GND		GND+0.5	V	3
Power Supply Rejection	PSR	See Note 4 below				4

**Notes:**

1. After internal AC coupling.
2. 20 – 80 %
3. Loss Of Signal is open collector to be pulled up with a 4.7k – 10kohm resistor to 3.15 – 3.6V. Logic 0 indicates normal operation; logic 1 indicates no signal detected.
4. Per Section 2.7.1. in the XFP MSA Specification.

## Optical Characteristics

(TOP = -5 to 70 C, VCC5 = 4.75 to 5.25 Volts)

Parameter	Symbol	Min	Typ	Max	Unit	Ref.
Transmitter						
Optical Modulation Amplitude (OMA)	POMA	-2.1			dBm	
Output Opt. Pwr: 9/125 SMF	Pout	-1		+3	dBm	
Optical Wavelength-End Of Life	$\lambda$	X-100	X	X+100	pm	
Transmitter Center Wavelength –Beginning Of Life	$\lambda$	X-25	X	X+25	pm	
Optical Extinction Ratio	ER	8.2			dB	
Transmitter and Dispersion Penalty	TDP			2	dB	
Average Launch power of OFF transmitter	POFF	-30			dBm	
Tx Jitter Generation (peak-to-peak)	Txj			0.1	UI	
Tx Jitter Generation (RMS)	TxjRMS			0.01	UI	



Receiver						
Receiver Sensitivity (OMA) @ 10.5Gb/s	RSENS			-16	dBm	
Maximum Input Power	PMAX	+0.5			dBm	
Optical Center Wavelength	$\lambda_C$	1270	1550	1600	nm	
Receiver Reflectance	Rrx			-27	dB	
LOS De-Assert	LOSD			-22	dBm	
LOS Assert	LOSA	-28			dBm	
LOS Hysteresis		1			dB	

## Pin Descriptions

Pin	Logic	Symbol	Name/Description	Ref.
1		GND	Module Ground	1
2		VEE5	Optional -5.2 Power Supply – Not required	
3	LVTTL-I	Mod-Desel	Module De-select; When held low allows the module to , respond to 2-wire serial interface commands	
4	LVTTL-O	Interrupt	Interrupt (bar); Indicates presence of an important condition which can be read over the serial 2-wire interface	2
5	LVTTL-I	TX_DIS	Transmitter Disable; Transmitter laser source turned off	
6		VCC5	+5 Power Supply	
7		GND	Module Ground	1
8		VCC3	+3.3V Power Supply	
9		VCC3	+3.3V Power Supply	
10	LVTTL-I	SCL	Serial 2-wire interface clock	2
11	LVTTL-I/O	SDA	Serial 2-wire interface data line	2
12	LVTTL-O	Mod_Abs	Module Absent; Indicates module is not present. Grounded in the module.	2
13	LVTTL-O	Mod_NR	Module Not Ready;	2
14	LVTTL-O	RX_LOS	Receiver Loss of Signal indicator	2
15		GND	Module Ground	1
16		GND	Module Ground	1
17	CML-O	RD-	Receiver inverted data output	
18	CML-O	RD+	Receiver non-inverted data output	
19		GND	Module Ground	1
20		VCC2	+1.8V Power Supply – Not required	
21	LVTTL-I	P_Down/	Power Down; When high, places the module in	



		RST	the low power stand-by mode and on the falling edge of P_Down initiates a module reset	
			Reset; The falling edge initiates a complete reset of the module including the 2-wire serial interface, equivalent to a power cycle.	
22		VCC2	+1.8V Power Supply – Not required	
23		GND	Module Ground	1
24	PECL-I	RefCLK+	Reference Clock non-inverted input, AC coupled on the host board – Not required	3
25	PECL-I	RefCLK-	Reference Clock inverted input, AC coupled on the host board – Not required	3
26		GND	Module Ground	1
27		GND	Module Ground	1
28	CML-I	TD-	Transmitter inverted data input	
29	CML-I	TD+	Transmitter non-inverted data input	
30		GND	Module Ground	1

**Notes:**

1. Module circuit ground is isolated from module chassis ground within the module.
2. Open collector; should be pulled up with 4.7k – 10k ohms on host board to a voltage between 3.15V and 3.6V.
3. A Reference Clock input is not required .

## Hostboard Connector Pinout

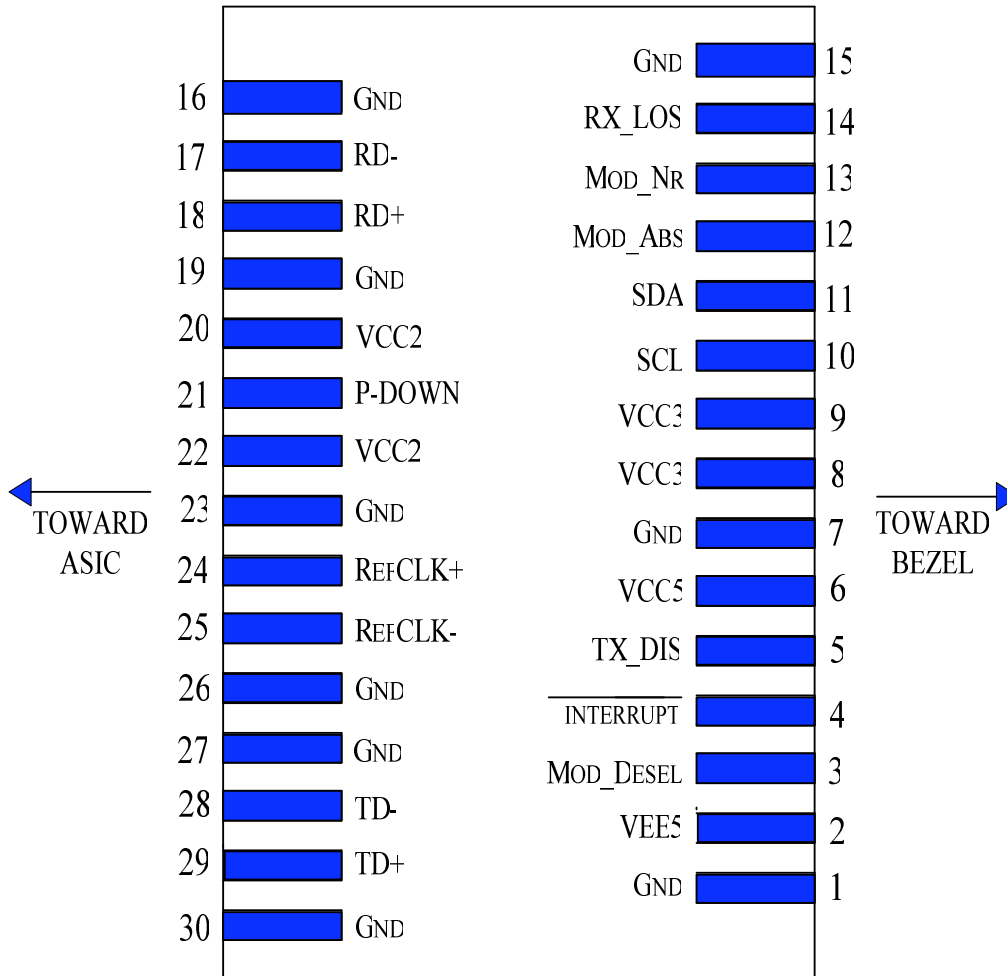

Diagram of Host Board Connector Block Pin Numbers and Name

## General Specifications

Parameter	Symbol	Min	Typ	Max	Units	Ref.
Bit Rate	BR	9.95		11.1	Gb/s	1
Bit Error Ratio	BER			10 <sup>-12</sup>		2
Max. Supported Link Length	LMAX		40		km	1

**Notes:**

1. SONET OC-192 IR-2, OC-192 IR-3, ITU-T G.709, 10GBASE-ER/EW + FEC, 10G Fibre Channel
2. Tested with a 2<sup>31</sup> – 1 PRBS

## Digital Diagnostic Functions

Eoptolink's EOLX-1596-40 Small Form Factor 10Gb/s (XFP) transceivers are compliant with the current XFP Multi-Source Agreement (MSA) Specification Rev 4.5.

As defined by the XFP MSA, Eoptolink XFP transceivers provide digital diagnostic functions via a 2-wire serial interface, which allows real-time access to the following operating parameters:

- ◆ Transceiver temperature
- ◆ Laser bias current
- ◆ Transmitted optical power
- ◆ Received optical power
- ◆ Transceiver supply voltage

It also provides a sophisticated system of alarm and warning flags, which may be used to alert end-users when particular operating parameters are outside of a factory-set normal range.

The operating and diagnostics information is monitored and reported by a Digital Diagnostics Transceiver Controller inside the transceiver, which is accessed through the 2-wire serial interface. When the serial protocol is activated, the serial clock signal (SCL pin) is generated by the host. The positive edge clocks data into the XFP transceiver into those segments of its memory map that are not write-protected. The negative edge clocks data from the XFP transceiver. The serial data signal (SDA pin) is bi-directional for serial data transfer. The host uses SDA in conjunction with SCL to mark the start and end of serial protocol activation. The memories are organized as a series of 8-bit data words that can be addressed individually or sequentially. The 2-wire serial interface provides sequential or random access to the 8 bit parameters, addressed from 000h to the maximum address of the memory.

## Recommended Host Board Power Supply Circuit

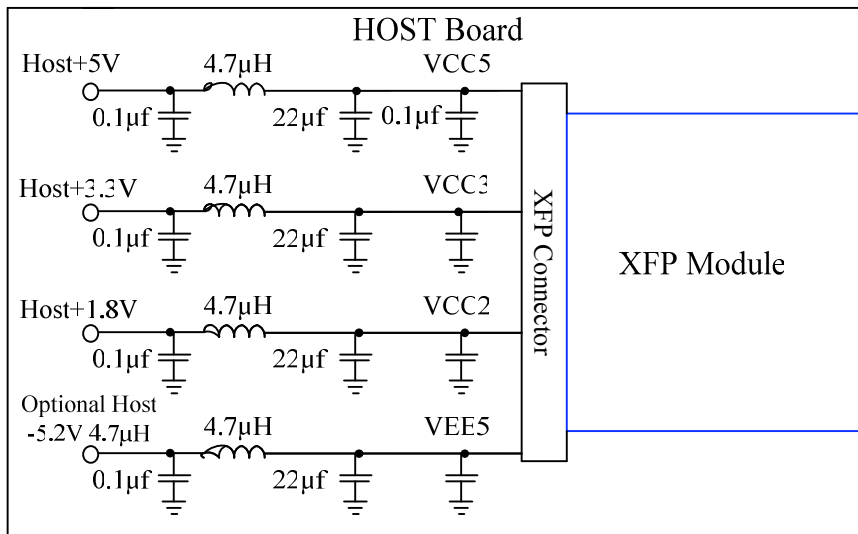

## Recommended High-speed Interface Circuit

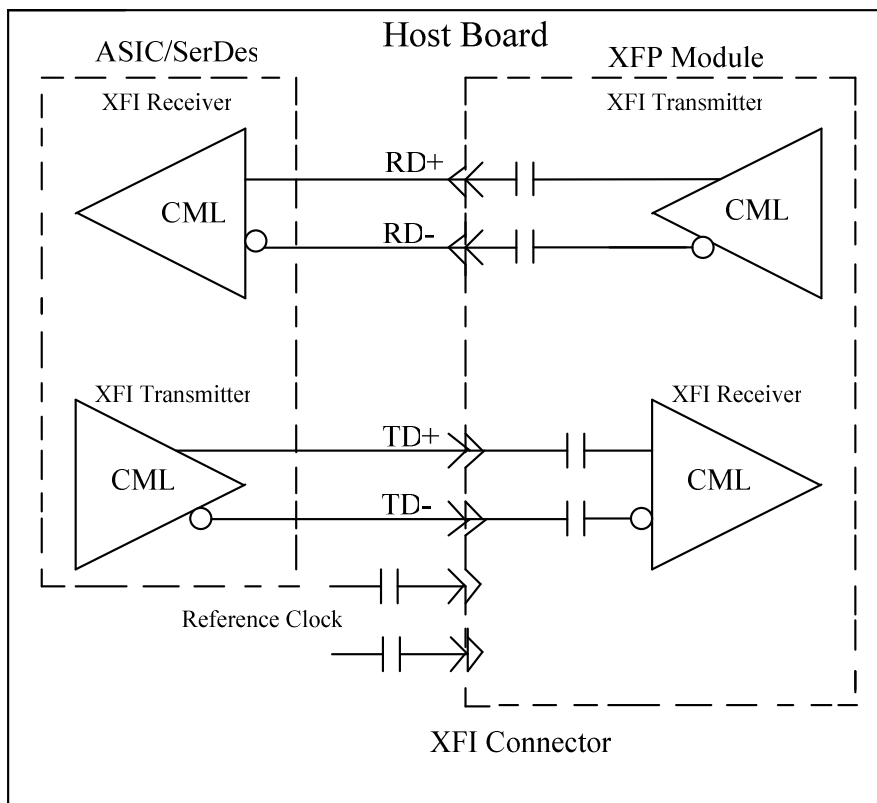

## Mechanical Specifications

Eoptolink's XFP transceivers are compliant with the dimensions defined by the XFP Multi-Sourcing Agreement (MSA).

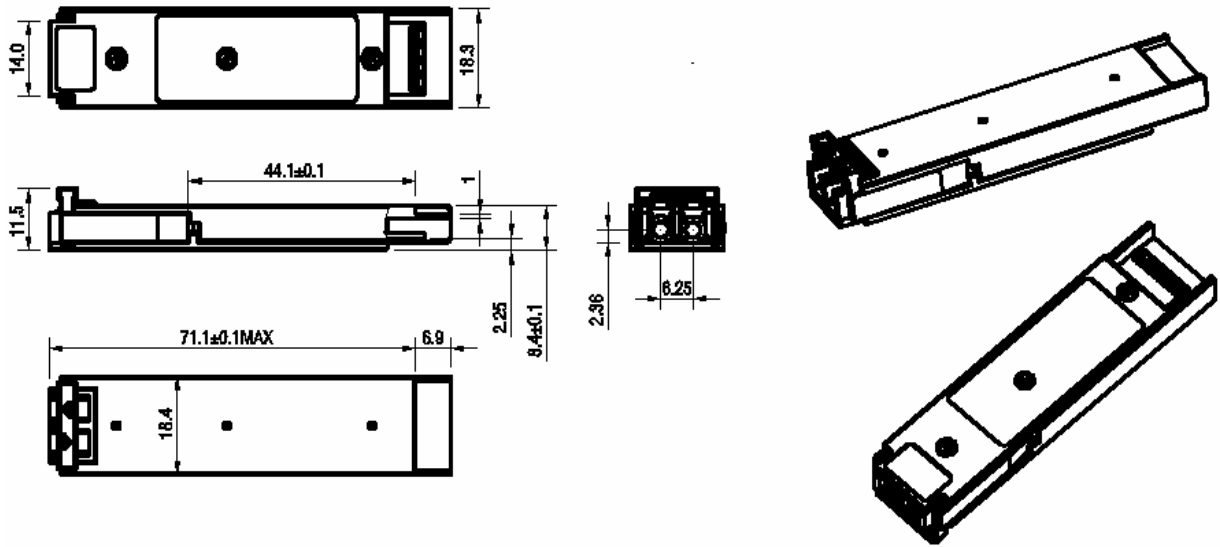

## Ordering information

Part No.	Data Rate	Laser	Fiber Type	Distance	Optical Interface
EOLX-1596-40X	10G	DFB EA	SMF	40Km	LC

X- Channel refer to page 2

**NOTICE:**

Eoptolink reserves the right to make changes to or discontinue any optical link product or service identified in this publication, without notice, in order to improve design and/or performance. Applications that are described herein for any of the optical link products are for illustrative purposes only. Eoptolink makes no representation or warranty that such applications will be suitable for the specified use without further testing or modification.

**CONTACT:**

**Add:** Floor 5, Building 2, No. 21 Gaopeng Avenue, High-Tech District, Chengdu City.

**Tel:** (+86) 028-85122709 ext 816 & 809

(+86) 028-85124308 ext 816 & 809

(+86) 028-85124306 ext 816 & 809

(+86) 028-85121709 ext 816 & 809

**Fax:** (+86) 028-85121912

**Postal:** 610041

**E-mail:** sales@eoptolink.com

<http://www.eoptolink.com>